





**CONTENUTO IMBALLO – PACKAGE CONTENTS – CONTENU DE L'EMBALLAGE – PACKUNGSINHALT – CONTENIDO DEL EMBALAJE**

- (I) Barriera di sicurezza con muting per la protezione delle persone (Elemento Attivo + Specchio) / Imballo (con accessori di fissaggio) / La presente guida di installazione
- (EN) Safety light curtain with muting for people protection (Active Element + Mirror) / Package accessoires (with assembly accessoires) / This quick installation guide
- (FR) Barrière de sécurité avec muting pour la protection des personnes (Élément Actif + Miroir) / Emballage (avec accessoires de fixation) / Le présent guide d'installation
- (D) Sicherheitslichtvorhang mit Muting zum Schutz von Personen (Aktives Element + Spiegel) / Packung (mit Befestigungszubehör) / Die vorliegende Installierungsanleitung
- (E) Barrera de seguridad con muting para la protección personal (Elemento Activo + Espejo) / Embalaje (con accesorios de fijación) / La presente guía de instalación

 <b>MANUAL</b>	<p><b>Per installare e utilizzare correttamente e sicuramente la barriera fotoelettrica, è NECESSARIO consultare il foglio di installazione ed il manuale</b></p> <p><b>To guarantee a correct and safe installation and operation of the light curtain, it is MANDATORY to consult the installation sheet and the user manual</b></p> <p><b>Pour installer et utiliser correctement et en sécurité la barrière photoélectrique, il est NECESSAIRE de consulter la feuille technique et le manuel d'instruction</b></p> <p><b>Zur richtigen und sicheren Installation und Anwendung der Lichtschranke, die Instruktionsanleitung und das technische Blatt MÜSSEN gelesen werden</b></p> <p><b>Para instalar y utilizar correctamente y con seguridad la barrera fotoeléctrica, SE DEBE consultar la hoja técnica y el manual de instrucciones</b></p>	 <b>SOFTWARE</b>
--	---	--

<https://www.reersafety.com/it/en/download>

	<p>→ I valori di sicurezza, i dati tecnici, le condizioni di garanzia e la Dichiarazione di Conformità sono contenute integralmente nel manuale.</p> <p>→ The safety values, technical data, warranty conditions and Declaration of Conformity are fully contained in the manual.</p> <p>→ Les valeurs de sécurité, caractéristiques techniques les conditions de garantie et la Déclaration de Conformité sont contenues dans le manuel dans leur intégralité.</p> <p>→ Die Sicherheitswerte, Technische Daten, Garantiebedingungen und Konformitätserklärung sind vollständig im Handbuch enthalten.</p> <p>→ Los valores de seguridad, datos técnicos, las condiciones de garantía y la Declaración de Conformidad se encuentran en el manual en su totalidad.</p>
---	---

<b>AVVERTIMENTI IMPORTANTI PER LA SICUREZZA DELLE PERSONE</b>	<ul style="list-style-type: none"> <li>⚠ Il sistema di sicurezza sia utilizzato solo come dispositivo di arresto e non come dispositivo di comando della macchina.</li> <li>⚠ Il comando della macchina sia controllabile elettricamente.</li> <li>⚠ Sia possibile interrompere prontamente ogni azione pericolosa della macchina. In particolare si deve conoscere il tempo di arresto della macchina, eventualmente misurandolo.</li> <li>⚠ La dimensione minima dell'oggetto che deve essere intercettato sia maggiore o uguale alla risoluzione del modello scelto.</li> <li>⚠ La conoscenza della forma e delle dimensioni della zona pericolosa permette di valutare la larghezza e l'altezza della sua area di accesso. Confrontare tali dimensioni con la massima portata utile e l'altezza dell'area controllata del modello utilizzato.</li> <li>⚠ Il mancato rispetto della distanza di sicurezza riduce o annulla la funzione protettiva della barriera.</li> <li>⚠ Durante tutta la fase in cui la funzione di OVERRIDE è attiva, la lampada di Override/Muting lampeggia. È necessario verificare periodicamente l'efficienza di questa lampada (durante le fasi di Muting oppure di Override).</li> <li>⚠ Il comando di Override ad impulso attiva automaticamente le uscite della barriera fino a che la barriera e i sensori di Muting non risultino nuovamente liberi da ostacoli. Durante tale periodo la barriera non è in grado di proteggere l'accesso al varco pericoloso. È quindi necessario che le operazioni vengano condotte sotto stretta sorveglianza di personale esperto.</li> <li>⚠ <b>Altre condizioni o limitazioni d'uso sono presenti integralmente sul manuale.</b></li> </ul>
---	--

<b>IMPORTANT WARNINGS CONCERNING THE SAFETY OF PERSONS</b>	<ul style="list-style-type: none"> <li>⚠ The safety system is only used as a stopping device and not as a machine control device.</li> <li>⚠ The machine control can be actuated electrically.</li> <li>⚠ All dangerous machine movements can be interrupted immediately. In particular, the machine stopping times must be known and, if necessary, measured.</li> <li>⚠ The minimum dimensions of the object that must be intercepted are greater than or equal to the resolution of the specific model.</li> <li>⚠ Knowledge of the shape and dimensions of the dangerous area enables the width and height of the relative access area to be calculated. Compare these dimensions with the maximum working range and the height of the protected area in relation to the specific model.</li> <li>⚠ The non-observance of the correct safety distance reduces or cancels the protective action of the light curtain.</li> <li>⚠ During the entire phase in which the OVERRIDE function is active, the Override/Muting lamp flashes. Periodically verify the efficiency of this lamp (during Muting or Override phases).</li> <li>⚠ The Pulse Override command automatically activates the curtain outputs until both the curtain and the Muting sensors are again free of obstacles. During this period the curtain is not able to protect access to the dangerous gate. It is therefore necessary that all operations be conducted under close supervision of experienced personnel.</li> <li>⚠ <b>Other conditions or limitations for use are available in the manual.</b></li> </ul>
--	---

<b>AVERTISSEMENT TRÈS IMPORTANT POUR LA SÉCURITÉ DU PERSONNEL</b>	<ul style="list-style-type: none"> <li>⚠ Le système de sécurité n'est utilisé que comme dispositif d'arrêt de la machine et non comme dispositif de commande la machine.</li> <li>⚠ La commande de la machine peut être contrôlée électriquement.</li> <li>⚠ Les mouvements dangereux de la machine peuvent être interrompus rapidement. Les temps d'arrêts doivent être connus ou mesurés.</li> <li>⚠ La dimension minimale de l'objet à intercepter doit être identique ou supérieure à la résolution de la barrière.</li> <li>⚠ Les dimensions et la configuration de la zone dangereuse doivent être connues pour définir la hauteur et la largeur du champ de protection. Comparer ces dimensions à la portée utile maximale et la hauteur de la zone contrôlée en fonction du type de barrière utilisé.</li> <li>⚠ Le non-respect de cette distance de sécurité réduit ou annule la fonction de protection de la barrière.</li> <li>⚠ Pendant toute la phase durant laquelle la fonction d'OVERRIDE est active, la lampe d'Override/Muting clignote. Il faut vérifier régulièrement l'efficacité de cette lampe (pendant les phases de Muting ou d'Override).</li> <li>⚠ La commande Override à impulsion active automatiquement les sorties de la barrière tant que celle-ci et les capteurs Muting ne sont de nouveau dégagés de tout obstacle. Pendant ce laps de temps, la barrière n'est pas en mesure de protéger l'accès au passage dangereux. D'où la nécessité d'exécuter tout les opérations sous la surveillance d'un personnel expérimenté.</li> <li>⚠ <b>D'autres conditions ou limitations d'utilisation figurent dans le manuel dans son intégralité.</b></li> </ul>
---	---

<b>SEHR WICHTIGE WARNUNG BETREFFEND DIE SICHERHEIT VON PERSONEN</b>	<ul style="list-style-type: none"> <li>⚠ Das Sicherheitssystem darf nur als Abschalteneinrichtung und nicht als Befehlsgerät für die Maschine verwendet werden.</li> <li>⚠ Der bewegte Maschinenteil ist elektrisch steuerbar.</li> <li>⚠ Es ist möglich, jede gefahrbringende Bewegung der Maschine sofort zu unterbrechen. Insbesondere muss die Anhaltezeit der Maschine bekannt sein: ggf. messen.</li> <li>⚠ Die zu erfassende Objekt-Mindestgröße muss gleich oder größer sein als die Auflösung des bestimmten Modells.</li> <li>⚠ Kenntnis von Form und Abmessungen des Gefahrenbereichs erlauben die Bewertung der Breite und Höhe des Zugangsbereichs. Vergleichen Sie diese Werte mit der maximalen Reichweite und der Schutzhöhe in Bezug auf das bestimmte Modell.</li> <li>⚠ Nichteinhalten des Sicherheitsabstands reduziert oder annulliert die Schutzfunktion der Lichtschranke.</li> <li>⚠ Während der gesamten Phase, in der die OVERRIDE-Funktion aktiv ist, blinkt die Override/Muting-Leuchte. Die Effizienz dieser Leuchte muss regelmäßig überprüft werden (während der Muting- oder Override-Phase).</li> <li>⚠ Der Override-Impulsbefehl aktiviert automatisch die Schrankenausgänge bis die Schranke und die Muting-Sensoren wieder befreit sind. Während dieser Zeit ist die Schranke nicht in der Lage, den Zugang zum gefährlichen Durchgang zu schützen. Alle Arbeiten müssen daher unter der strikter Überwachung fachkundigen Personals durchgeführt werden.</li> <li>⚠ <b>Weitere Bedingungen oder Einschränkungen für die Verwendung finden Sie im Handbuch.</b></li> </ul>
---	--

<b>AVISO IMPORTANTE PARA LA SEGURIDAD DE LAS PERSONAS</b>	<ul style="list-style-type: none"> <li>⚠ El sistema de seguridad sea utilizado únicamente como dispositivo de parada y no como dispositivo de accionamiento de la máquina.</li> <li>⚠ El accionamiento de la máquina sea controlable eléctricamente.</li> <li>⚠ Sea posible interrumpir rápidamente cada acción peligrosa de la máquina: En particular se debe conocer el tiempo de parada de la máquina, eventualmente midiéndolo.</li> <li>⚠ La dimensión mínima del objeto que debe ser interceptado sea mayor o igual que la resolución del modelo elegido.</li> <li>⚠ El conocimiento de la forma y de las dimensiones de la zona peligrosa permite estimar la anchura y altura de su área de acceso. Comparar tales dimensiones con el alcance máximo útil y la altura del área controlada del modelo utilizado.</li> <li>⚠ La falta de respeto de la distancia de seguridad reduce o anula la función de protección de la barrera.</li> <li>⚠ Durante toda la fase en que la función de OVERRIDE está activa, la luz de Override/Muting parpadea. Es necesario comprobar periódicamente la eficacia de esta luz (durante las fases de Muting o de Override).</li> <li>⚠ El mando de Override por pulso activa automáticamente las salidas de la barrera mientras que, tanto la barrera como los sensores de Muting, no estén otra vez libres de obstáculos. Durante ese periodo, la barrera no está en condiciones de proteger el acceso al paso peligroso. Por lo tanto, es necesario que todas las operaciones se realicen bajo la estricta supervisión de personal experto.</li> <li>⚠ <b>Otras condiciones o limitaciones de uso se encuentran en el manual en su totalidad.</b></li> </ul>
---	--

**A) MONTAGGIO MECCANICO – MECHANICAL ASSEMBLY – MONTAGE MECANIQUE – BEFESTIGUNG – MONTAJE MECÁNICO**

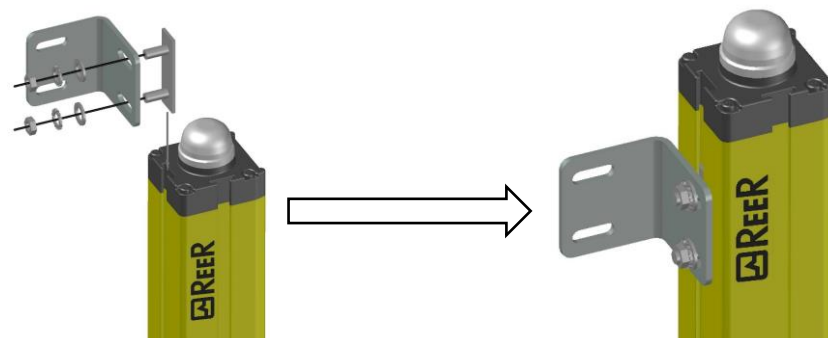

**B) COLLEGAMENTI ELETTRICI – ELECTRICAL CONNECTIONS – BRANCHEMENTS ELECTRIQUES – ELEKTRISCHE ANSCHLÜSSE – CONEXIONES ELÉCTRICAS**

⚠ L'Elemento Attivo deve essere alimentato con tensione di 24Vdc±20%. L'alimentazione esterna deve essere conforme alla EN 60204-1.  
 ⚠ The Active Element must be supplied with 24Vdc±20% power. The external power supply must comply with the standard EN 60204-1.  
 ⚠ L'Élément Actif doit être alimenté par une tension continue 24VDC±20%. L'alimentation doit être conforme à la norme EN 60204-1.  
 ⚠ Das Aktive Element muss mit 24Vdc±20% Spannung versorgt werden. Die externe Stromversorgung muss der EN 60204-1 entsprechen.  
 ⚠ El Elemento Activo debe ser alimentado con una tensión de 24Vdc±20%. La alimentación externa debe ser conforme a la norma EN 60204-1.

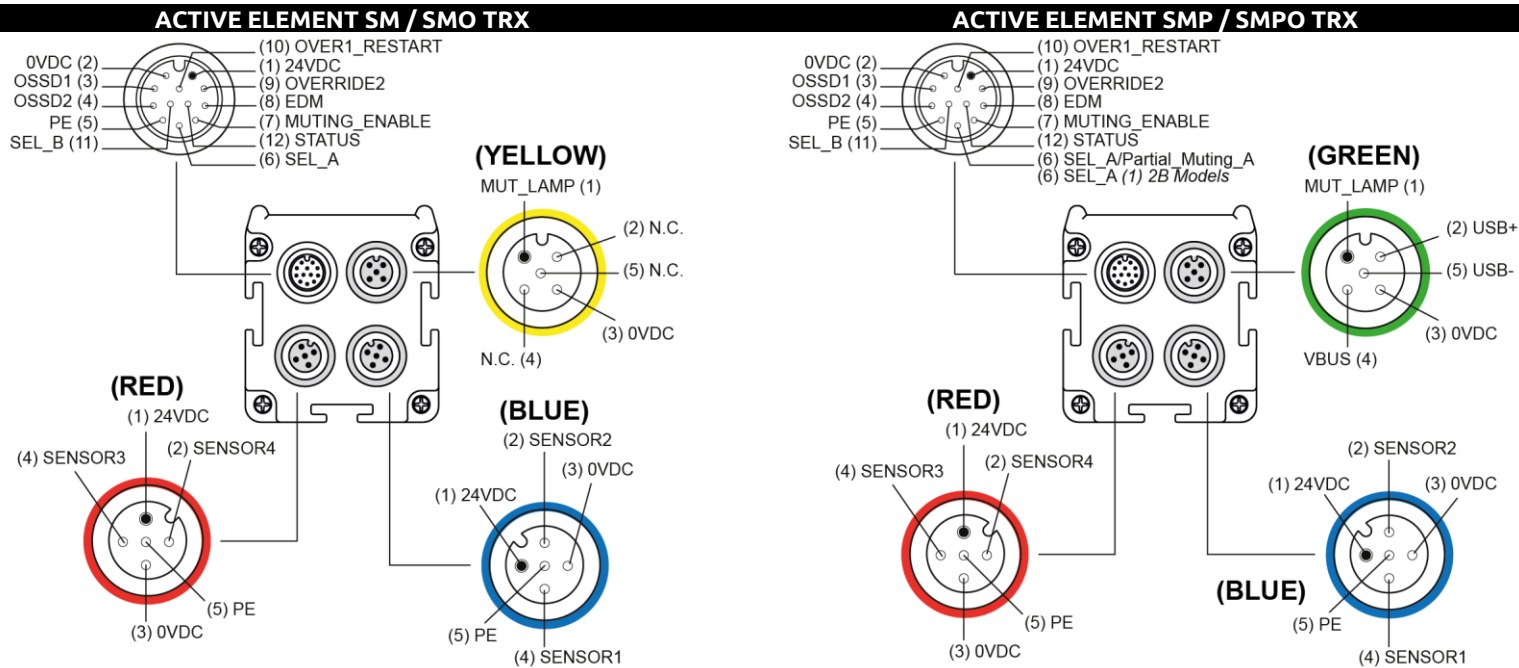

ACTIVE ELEMENT CONNECTIONS				
PRIMARY - M12 - 12 PIN MALE CONNECTOR				
PIN	COLOUR	SIGNAL	IN/OUT	DESCRIPTION
1	Brown	24VDC	-	24VDC power supply
2	Blue	0VDC	-	0VDC power supply
3	White	OSSD1	Output	Safety static outputs
4	Green	OSSD2	Output	
5	Pink	PE	-	Earth connection
6	Yellow	SEL_A	Input	Muting configuration
		PARTIAL_MUTING_A <sup>(2)(3)</sup>		Partial Muting Control
7	Black	MUT_ENABLE	Input	External Muting Enable
8	Grey	EDM	Input	K1/K2 Feedback
9	Red	OVERRIDE2	Input	Override Request
10	Purple	OVERRIDE1	Input	Override Request
		RESTART		Restart Interlock
11	Grey/Pink	SEL_B	Input	Muting configuration
12	Red/Blue	STATUS	Output	System Status

SENSORS 1-2 - M12 - 5 PIN FEMALE CONNECTOR (BLUE)				
PIN	COLOUR	SIGNAL	IN/OUT	DESCRIPTION
1	Brown	24VDC	-	24VDC sensors power supply
2	White	SENSOR2	Input	SENSORS 2 status
3	Blue	0VDC	-	0VDC
4	Black	SENSOR1	Input	SENSORS 1 status
5	Grey	PE	-	Earth connection

SENSORS 3-4 - M12 - 5 PIN FEMALE CONNECTOR (RED)				
PIN	COLOUR	SIGNAL	IN/OUT	DESCRIPTION
1	Brown	24VDC	-	24VDC sensors power supply
2	White	SENSOR4	Input	SENSORS 4 status
3	Blue	0VDC	-	0VDC
4	Black	SENSOR3	Input	SENSORS 3 status
5	Grey	PE	-	Earth connection

USB/MUTING LAMP CONNECTOR (YELLOW/GREEN)					
PIN	COLOUR	SM/SMO SIGNAL (YELLOW)	SMP/SMPO SIGNAL (GREEN)	IN/OUT	DESCRIPTION
1	Brown	MUT_LAMP	MUT_LAMP	Output	Active muting 24VDC
2	White	n.c.	USB+	Input/Output	-
3	Blue	0VDC	0VDC	-	0VDC
4	Black	n.c.	VBUS	Input	5VDC
5	Grey	n.c.	USB-	Input/Output	-

(1) For 2B Models "Partial Muting A" is not available  
 (2) PARTIAL\_MUTING signal is present only on programmable models (SMP/SMPO)  
 (3) Not applicable for 2B Models

- ⚠ Verificare che i settaggi dell'Elemento Attivo (automatico/manuale, controllo relè esterni, ecc.) corrispondano a quelli voluti! Tale operazione va compiuta prima dell'accensione, altrimenti il sistema non funziona!
- ⚠ Per un corretto funzionamento della barriera SAFEGATE (solo per modelli SMP/SMPO con richiesta lampada selezionata via software) è necessario collegare una lampada di segnalazione Muting Attivo.
- ⚠ Verify that the setting of Active Element (automatic / manual restart, external relay monitoring) match your installation requirements. This operation has to be performed before power up, otherwise the system will not work!
- ⚠ For a SAFEGATE light curtain (only for SMP/SMPO models with lamp request selected via software) correct operation the muting lamp must be connected.
- ⚠ Vérifier si les configurations de l'Élément Actif (automatique/manuel, contrôle relais externes, etc.) correspondent à celles qui sont préconisées. Cette opération doit être exécutée avant la mise en marche, autrement le système ne peut pas fonctionner !
- ⚠ Pour un fonctionnement correct de la barrière SAFEGATE (Uniquement pour les modèles SMP / SMPO avec demande lampe sélectionné via le logiciel) il faut raccorder une lampe de signalisation Muting Actif.
- ⚠ Stellen Sie sicher, dass die Einstellungen des Aktiven Elements (automatisch/manuell, externe Relais-Kontrolle, etc.) mit den beabsichtigten übereinstimmen! Dieser Vorgang muss vor dem Einschalten durchgeführt werden, da das System sonst nicht funktioniert!
- ⚠ Für eine korrekte Funktionsweise der Lichtschranke SAFEGATE (Nur für SMP/SMPO Modelle mit Lampe Anforderung durch Software ausgewählt) muss eine Signalleuchte Muting Aktiv angeschlossen werden.
- ⚠ ¡Comprobar que las configuraciones del Elemento Activo (automático/manual, control relés externos, etc.) correspondan a las deseadas! Esta operación se debe llevar a cabo antes del encendido; ¡de lo contrario, el sistema no funciona!
- ⚠ Para que la barrera SAFEGATE (Sólo para los modelos SMP / SMPO con solicitud lámpara seleccionada a través del software) funcione correctamente, es necesario conectar una luz de indicación de Muting Activo.

**C) ALLINEAMENTO OTTICO – OPTICAL ALIGNMENT – ALIGNEMENT OPTIQUE – OPTISCHE AUSRICHTUNG – ALINEAMIENTO ÓPTICO**

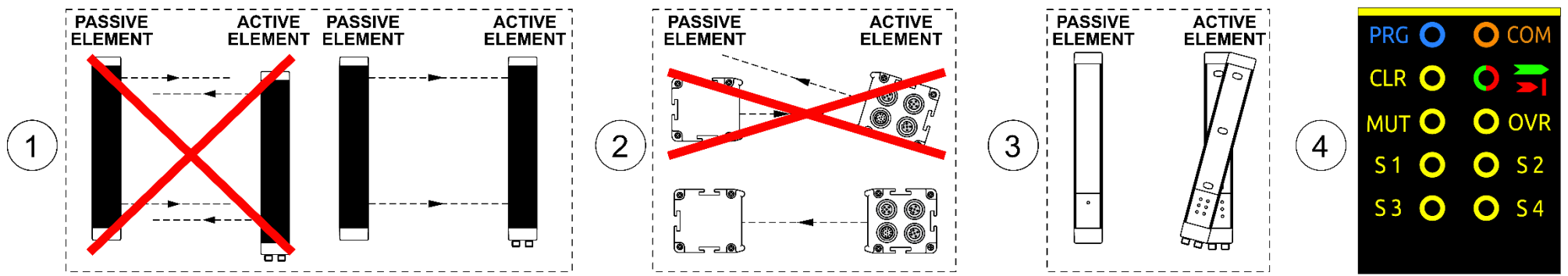

- I** • (1) Posizionare l'asse ottico del primo e dell'ultimo raggio dello Specchio sullo stesso asse di quello dei corrispondenti raggi sull'Elemento Attivo. (2) Muovere lo Specchio per trovare l'area entro la quale il led verde sull'Elemento Attivo rimane acceso, quindi posizionare il primo raggio dello Specchio (quello vicino ai led di segnalazione) al centro di quest'area. (3) Usando questo raggio come perno, con piccoli spostamenti laterali dell'estremità opposta portarsi nella condizione di area controllata libera che, in questa situazione, sarà indicata dall'accensione del led verde (4) sull'Elemento Attivo. **Se il LED COM diventa blu il segnale ricevuto è debole.** Serrare stabilmente lo Specchio e l'Elemento Attivo.
- Le applicazioni più comuni utilizzando modelli SAFEGATE (e sensori di muting esterni) sono descritte approfonditamente nel manuale tecnico. Seguire le indicazioni della Normativa IEC TS 62046 allo scopo di effettuare una corretta installazione dei sensori esterni.
- EN** • (1) Position the optical axis of the first and last beam of the Mirror on the same axis as that of the corresponding beams on the Active Element. (2) Move the Mirror in order to find the area within which the green LED on the Active Element stays on, then position the first beam of the Mirror (the one close to the indicator LEDs) in the centre of this area. (3) Using this beam as a pivot, effect small sideways movements of the opposite end to move to the protected area clear condition. (4) The green LED on the Active Element will indicate this condition. **If the COM LED turns blue, the received signal is weak.** Lock the Mirror and Active Element in place.
- The most common applications using SAFEGATE models (and external muting sensors) are described in detail in the technical handbook. Follow the recommendations of IEC TS 62046 to ensure correct installation of external sensors.
- FR** • (1) Positionner les axes optiques du premier et du dernier faisceau du Miroir en coïncidence avec les axes des faisceaux correspondants du Élément Actif. (2) Déplacer le Miroir pour trouver la zone dans laquelle la DEL verte du Élément Actif reste allumée et positionner le premier faisceau de le Miroir (celui le plus proche des DEL de signalisation) au centre de cette zone. (3) En utilisant ce faisceau comme pivot fictif et en imprimant de faibles déplacements latéraux à l'extrémité opposée, rechercher la condition de zone contrôlée libre qui sera indiquée par l'éclairage de la DEL verte (4) sur le Élément Actif. **Si la DEL COM devient bleue, le signal reçu est faible.** Fixer solidement le Miroir et le Élément Actif.
- Les applications les plus communes utilisant des modèles SAFEGATE (et des capteurs de muting externes) sont décrites de manière plus approfondie dans le manuel technique. Suivre les indications de la Réglementation IEC TS 62046 en vue d'effectuer une installation correcte des capteurs externes.
- D** • (1) Eine optimale Ausrichtung erreicht man, indem man die optischen Achsen des ersten und des letzten Strahls des Spiegels mit den entsprechenden Strahlenachsen des Aktives Element in Übereinstimmung bringt. (2) Den Spiegel bewegen, um den Bereich zu finden, in dem die grüne LED am Aktives Element "AN" bleibt. Dann den ersten Strahl des Spiegel (in der Nähe der LED-Anzeige) in die Mitte dieses Bereichs bringen. (3) Diesen Strahl nun als gedachten Fixpunkt benutzen und durch kleine Seitwärtsbewegungen des anderen Endes den Zustand "Schutzzone frei" ermitteln, was durch Aufleuchten der grünen LED (4) am Aktives Element angezeigt wird. **Wenn die COM-LED blau leuchtet, das empfangene Signal schwach ist.** Spiegel und Aktives Element festschrauben.
- Die geläufigsten Anwendungen unter Verwendung der Modelle SAFEGATE (und externer Muting-Sensoren) sind ausführlich in der technischen Anleitung. Für eine korrekte Installation der externen Sensoren folgen Sie bitte den Angaben der Vorschrift IEC TS 62046.
- E** • (1) Posicionar el eje óptico del primero y del último rayo del Espejo en el mismo eje que corresponde a los rayos del Elemento Activo. (2) Mover el Espejo para encontrar el área dentro de la cual el LED verde del Elemento Activo permanece encendido, después posicionar el primer rayo del Espejo (el cercano al LED de señalización) al centro de ésta área. (3) Utilizando este rayo como eje, con pequeños desplazamientos laterales del extremo opuesto colocarse en la situación de área controlada libre que, en esta situación, estará indicada por el encendido del LED verde (4) en el Elemento Activo. **Si el LED COM se ilumina en azul, la señal recibida es débil.** Fijar establemente el Espejo y el Elemento Activo.
- Las aplicaciones más comunes donde se utilizan los modelos SAFEGATE (y sensores de muting externos) se describen detalladamente en el manual técnico contenido en el CD-ROM adjunto (cuando esté disponible). Seguir las indicaciones de la Norma IEC TS 62046 para llevar a cabo una correcta instalación de los sensores externos.

**D) SCHEMI DI CONNESSIONE – WIRING DIAGRAMS – SCHÉMAS ÉLECTRIQUES – SCHALTPLÄNE – ESQUEMAS DE CONEXIÓN**

**1 - Wiring Configuration  
MUTING MODES OF OPERATION (MANUAL MODE)**

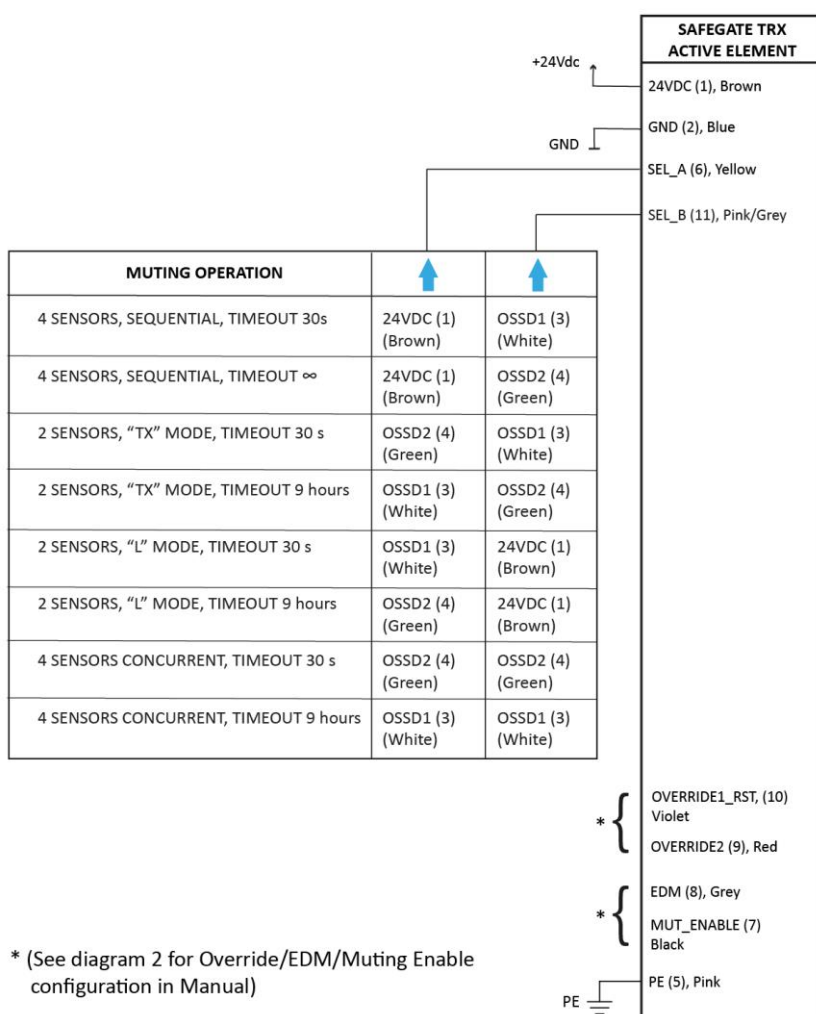

**2 - Wiring Configuration  
OVERRIDE/EDM/MUTING ENABLE (MANUAL MODE)**

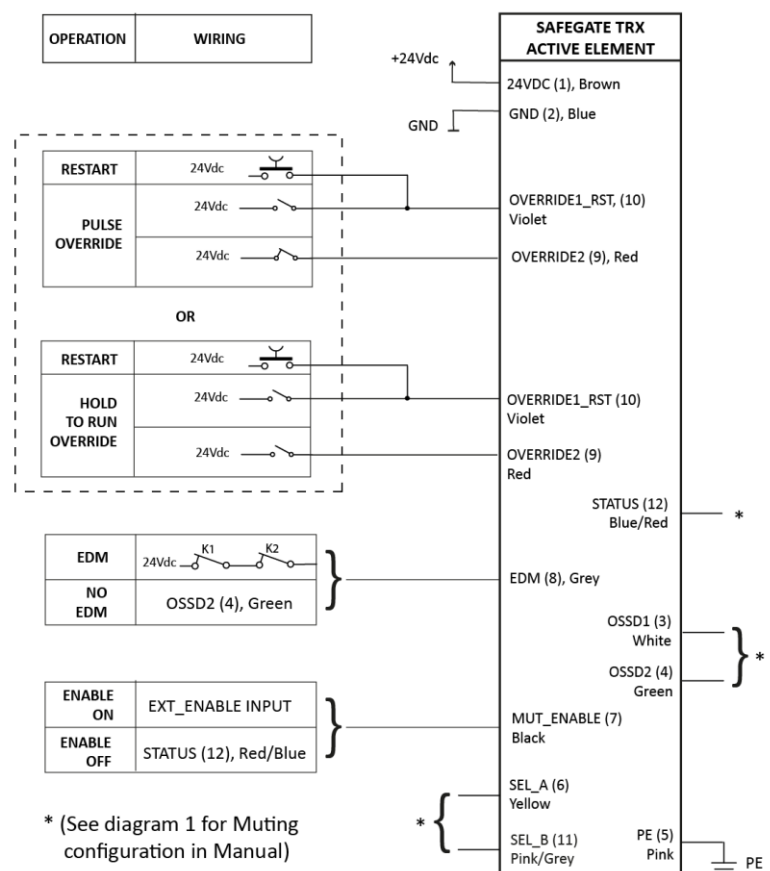

**3 - Wiring Configuration**  
**MUTING MODES OF OPERATION (AUTOMATIC MODE)**

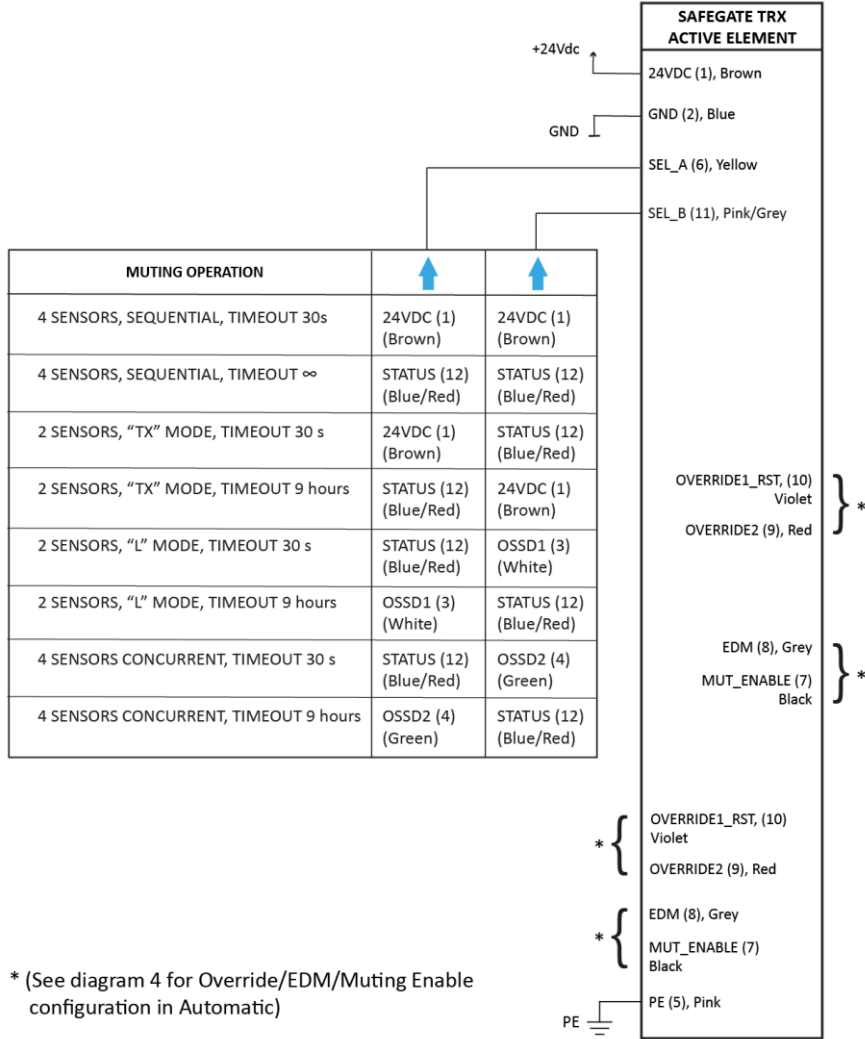

**4 - Wiring Configuration**  
**VERRIDE/EDM/MUTING ENABLE (AUTOMATIC MODE)**

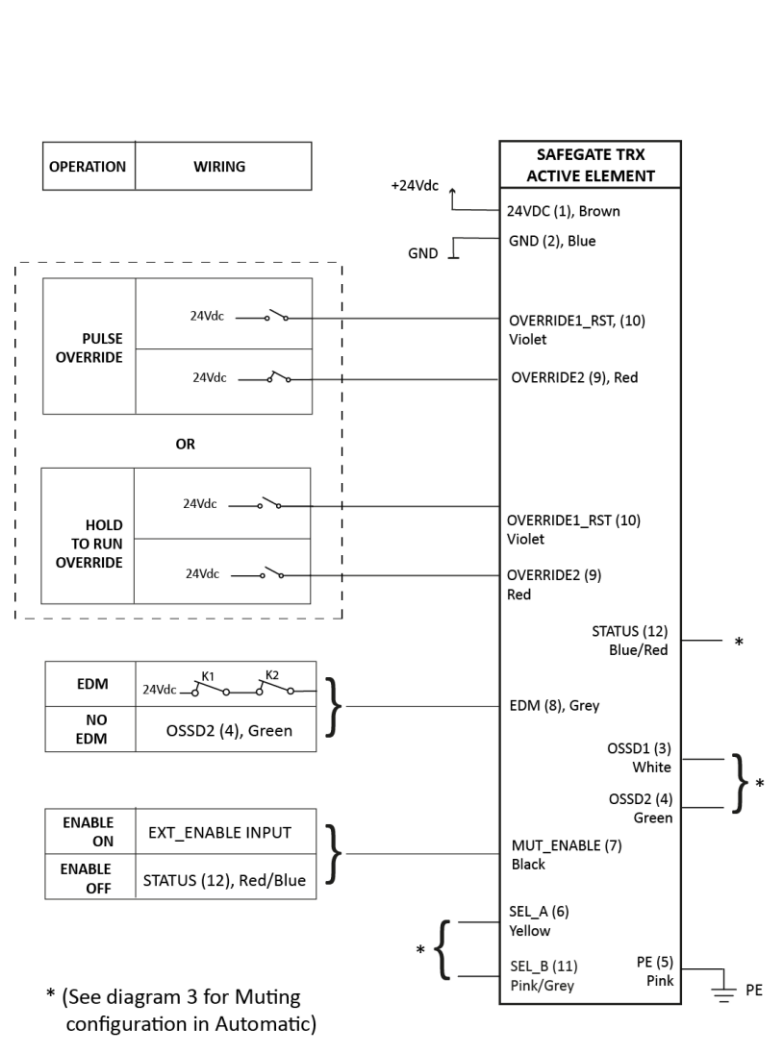

**5 - SOFTWARE CONFIGURATION**

